

Continuous network discovery using Opportunistic Scanning

Date: 2009-11-17

Authors:

| Name | Affiliations | Address | Phone | email |
|-----------------|-----------------------------|--|--------------------------|----------------------|
| Marc Emmelmann | Technical University Berlin | Einsteinufer 25 10587 Berlin Germany | +49 - 177 - 213 12 05 | emmelmann@ieee.org |
| Sven Wiethölter | | | | wiethoelter@ieee.org |
| Hyung-Taek Lim | | | | lim@tkn.tu-berlin.de |
| | | | | |
| | | | | |

Abstract

This presentation is in response to WNG requesting more information on the capability of 802.11 to support seamless handover / network discovery in order to enable in the long term the support of (highly) mobile users.

It explores how IEEE 802.11 Power Save can be used in combination with passive scanning to continuously scan for available networks in the STA's proximity.

The presented approach assures that even though passive scanning is used, the interruption time experienced on application level (above MAC) is short enough to support real time application QoS constrains.

IEEE 802.11: From nomadic to mobile wireless access – there is a market

- **IEEE 802.11 is still a nomadic wireless access technology (def. by ITU-R F.1399-1) but mobile wireless access service models are one major aspect of future markets.**
- **Beyond nomadic: we do it today but we are not mobile**
 - Wi-Fi IP mobile phone (not only in-house phone)
 - Wi-Fi on a car (high context navigation)
 - Wi-Fi on a train (passenger services)
 - Wi-Fi real-time audio (anywhere anytime)
 - Wi-Fi real-time video (anywhere anytime)
 - skype, etc.,
- **It is feasible: in a lot of existing WiFi Areas, STAs receive a signal from several APs at any time**

Source: 11-09/1000r1 [6]

What needs to be explored

- **PHY**
- **MAC**
- **Fast Handover for mobile (vehicular) users**
 - 11k can already reduce the latency
 - Other schemes, e.g.: background scanning
- **Include mobility support in 802.11?**
- **Are existing mechanisms sufficient?**

| WNG Straw Polls | Y | N | More Dis. | Abst. |
|---|----|---|-----------|-------|
| Should 802.11 proceed to mobile communication [6] | 8 | 0 | 15 | 0 |
| Should IEEE 802.11 WNG receive further presentations on the topic of enhancement technology for vehicular communications? [7] | 13 | 0 | 18 | |

- **This talk: feasibility & performance analysis of continuous background scanning with 802.11**

Why frequent / continuous network discovery?

- **Network discovery: detecting (other) systems / networks / technologies**
- **Examples:**
 - Alternative systems to conduct a handover to
 - Due to mobility / service constraints
 - Homogeneous
 - Heterogeneous (software-defined radio, single NIC)
 - Regularly listen to channel to evaluate, e.g. interference conditions etc.
 - Detect primary users if operating in white space
- **Network discovery is required to be conducted in parallel to ongoing communication either due to juridical or performance constraints**
- **How to conduct network discovery without affecting the ongoing communication**
 - upholding the QoS constraints of real-time applications,
 - in a simple, effective, and implementable way ?
- **How does the scanning scheme effect the performance of the system (other stations)?**

Contributions

- **Present the concept of Opportunistic Scanning**
- **Show how Opportunistic Scanning can be applied to IEEE 802.11 in an entirely standard compliant way**
- **Performance evaluation of Opportunistic Scanning considering all the protocol overhead induced for using 802.11 power save as a signaling protocol**
 - Theoretical performance limits of Opportunistic Scanning
→ minimal achievable service interruption
 - Classify the success probability of Opportunistic Scanning in order to find an existing network
 - Effect of (heavy) background load on the reliability of Opportunistic Scanning
 - Performance of Opportunistic Scanning within a VoIP scenario

Network Discovery Phases

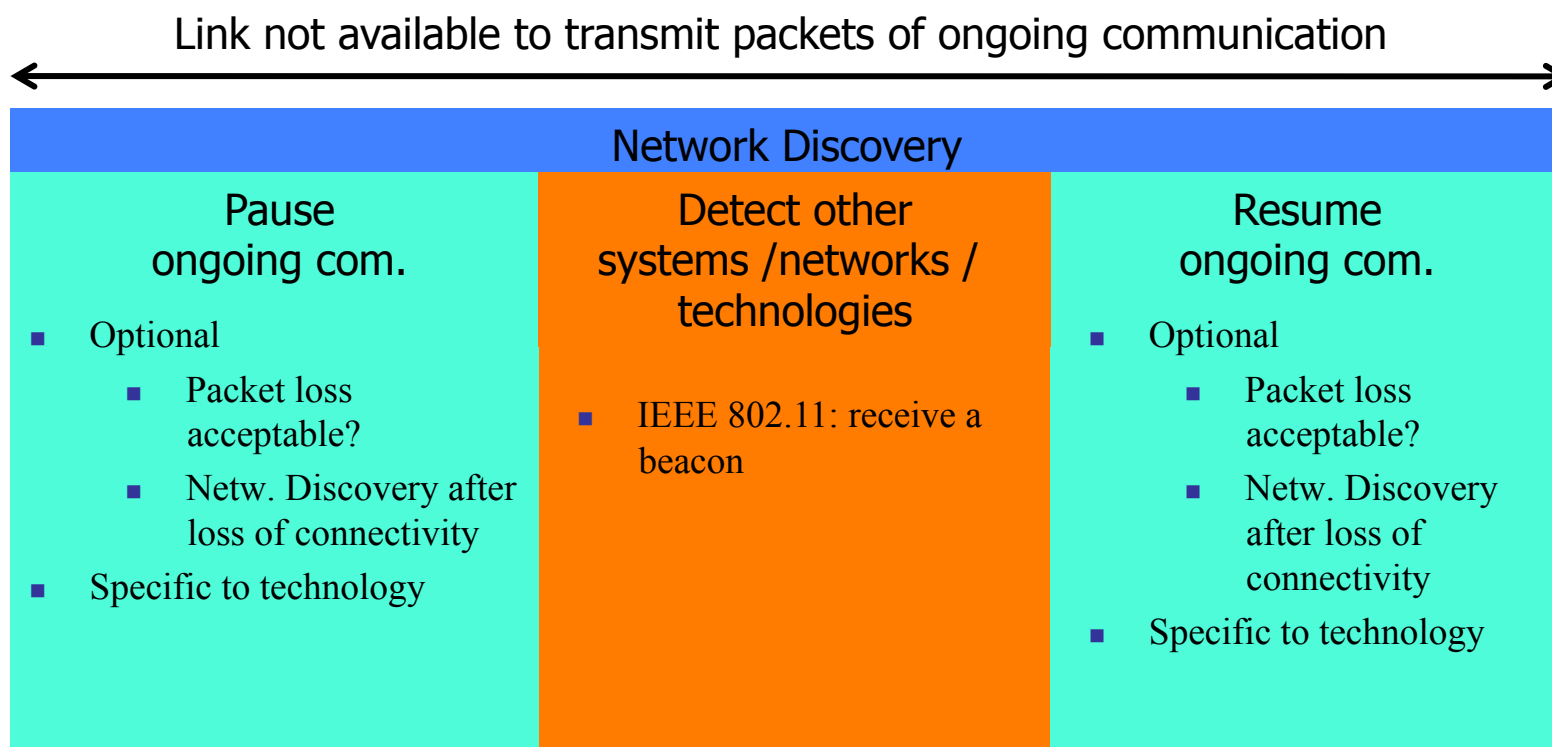

Assumptions -> Opportunistic Scanning Approach:

- a/ Interruption of Link does not affect QoS of higher layer applications if interruption time is shorter than a given (application specific) threshold.
- b/ Technology to be discovered regularly emits a detectable pattern

Opportunistic Scanning

- **Conduct network discovery regularly at time intervals**
 - not affecting the QoS constraints of higher layer applications
 - being smaller than the rate at which the “detectable pattern” is transmitted
→ finding a technology becomes a stochastic process
- **Constraint: do not impose any load on the channel where other devices are to be detected**
 - Important if approach shall scale
 - Occasionally not allowed by juridical requirements

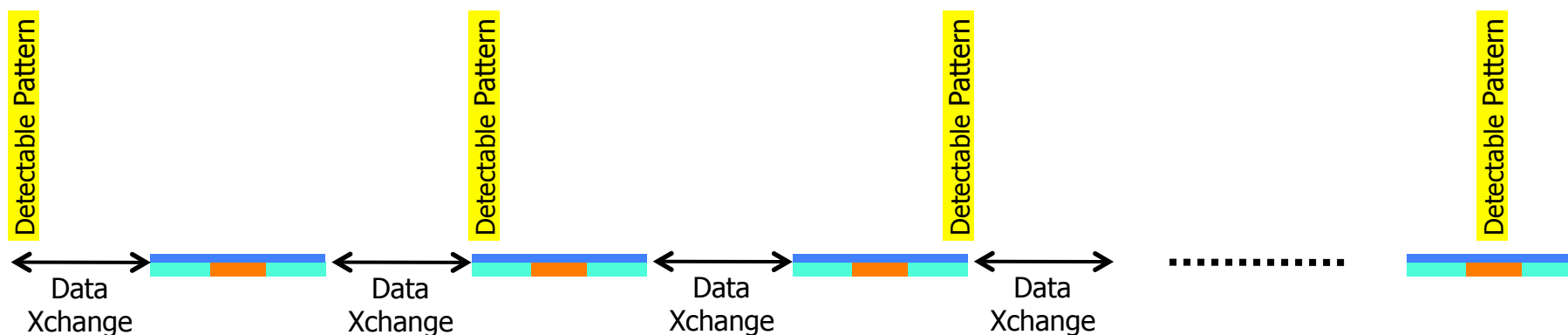

- This technology independent approach has to be applied to a specific technology by
 - deciding on a signaling mechanisms / protocol for pausing & resuming communication
 - Deciding which other technologies to detect
- [In the following: apply Opportunistic Scanning to IEEE 802.11](#)

Using Power Save to pause ongoing communication

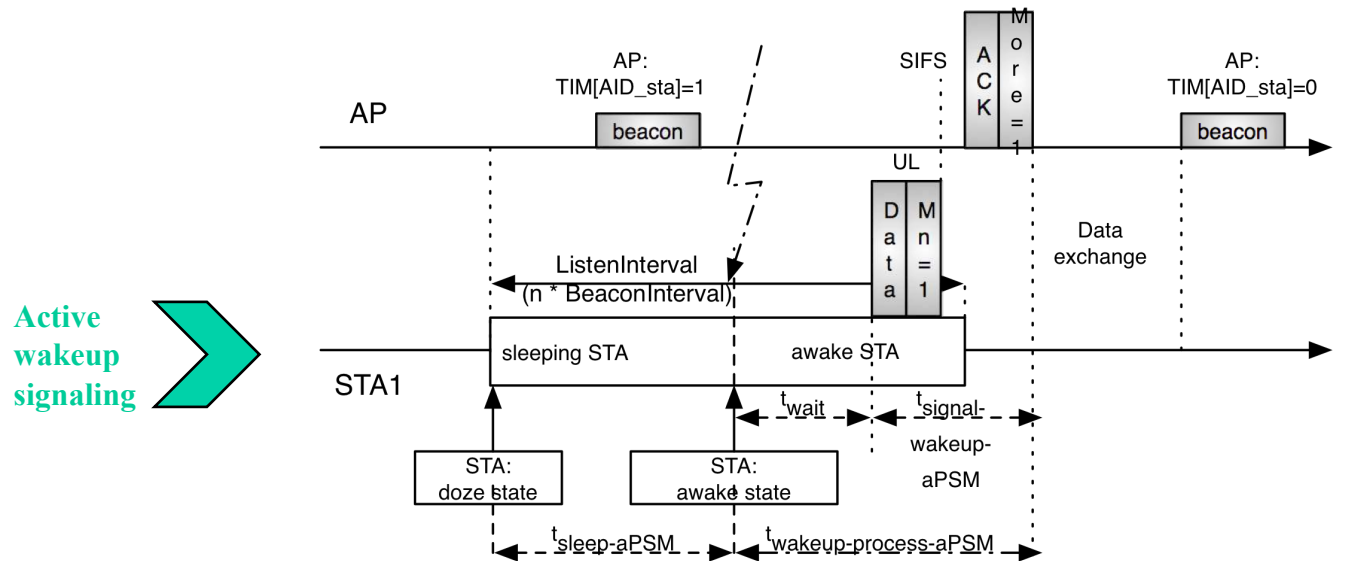
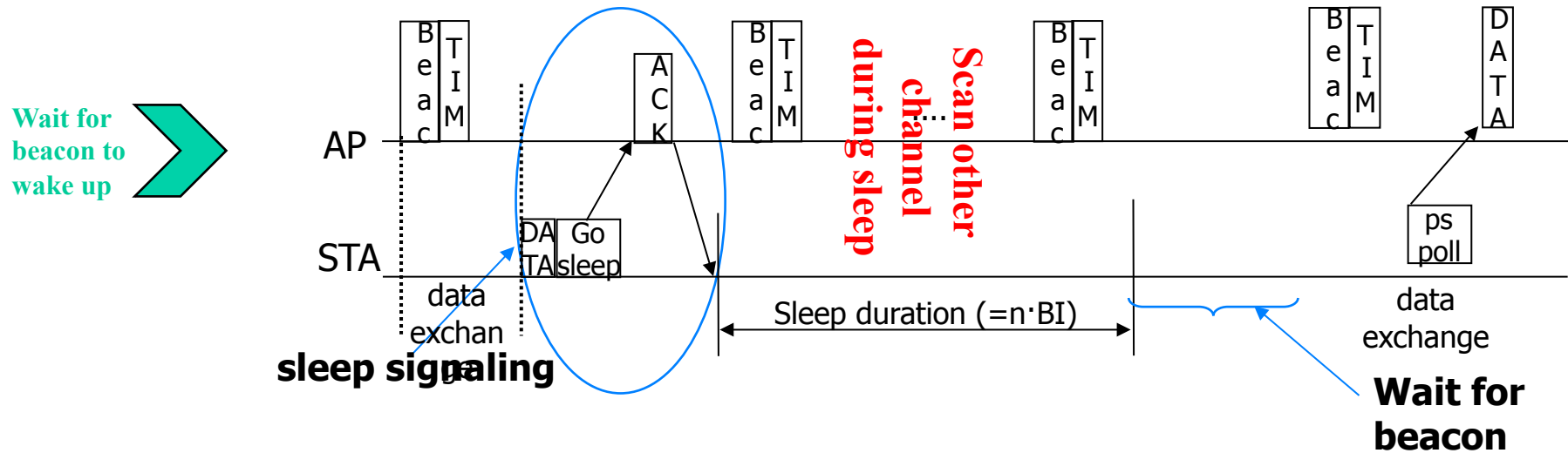

- Power saving as a signaling protocol for opportunistic Scanning seems feasible for real time applications
- Smallest achievable service interruption determines performance limit

Theoretical Performance Limit

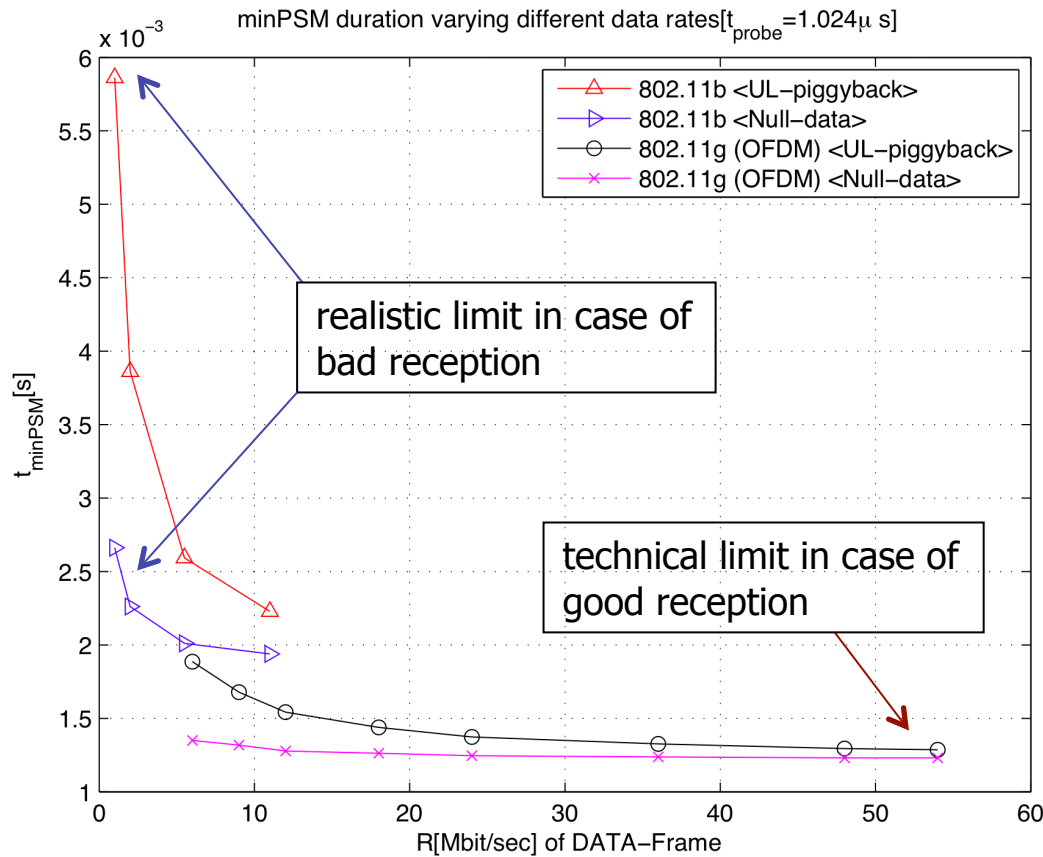

⇒ Two cases:

- a/ Null-Data for signaling
- b/ VoIP application G711

⇒ **PSM is feasible for using real time applications, if packet IAT is greater than**

$$t_{min-psm}$$

⇒ smallest supportable IAT : 1.25ms
approx. 2.75ms for low MCS

⇒ **Opportunistic Scanning in combination with 802.11 power save can be applied to real-time services**

Analytical derived results, formulas given in [1]

Analysis: Time required to find a beacon

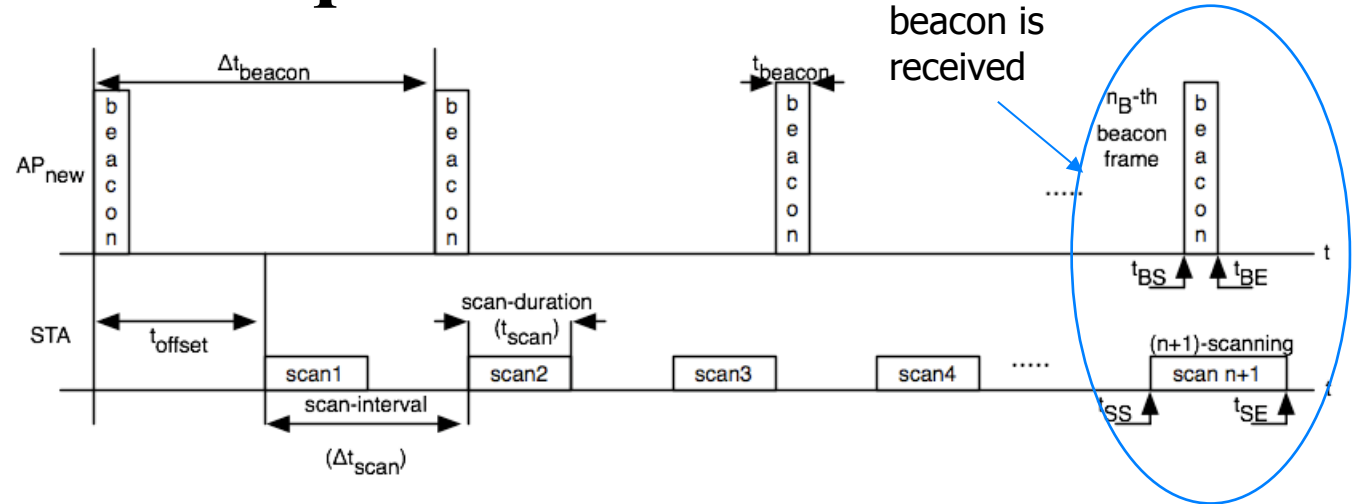
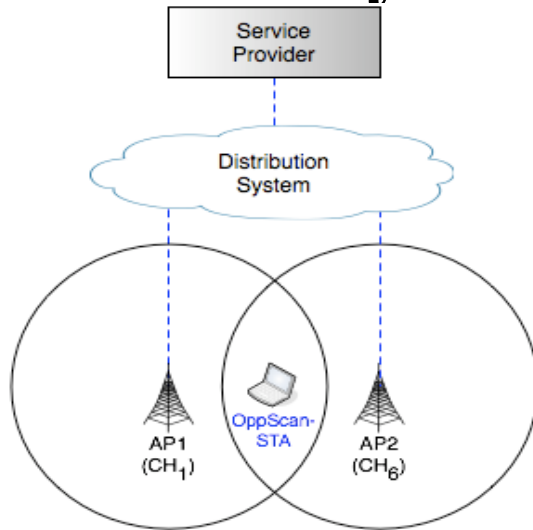

Analytical Results:

- **STA in overlap of two APs**
- **Tries to discover AP2 using OpSCAN**
- **No interference, no other BG-traffic**
- **Beacon transmission not synchronized with scanning process**
- **Signaling carried in Null Data Frames**

$$\frac{n_B \cdot \Delta t_{beacon} - t_{offset}}{\Delta t_{scan}} - \left(\frac{t_{scan} - t_{beacon}}{\Delta t_{scan}} \right) \leq n_{scan} \leq \frac{n_B \cdot \Delta t_{beacon} - t_{offset}}{\Delta t_{scan}}$$

(n_B : number of beacon frames)

Details given in [1]

Influence of Scan Interval

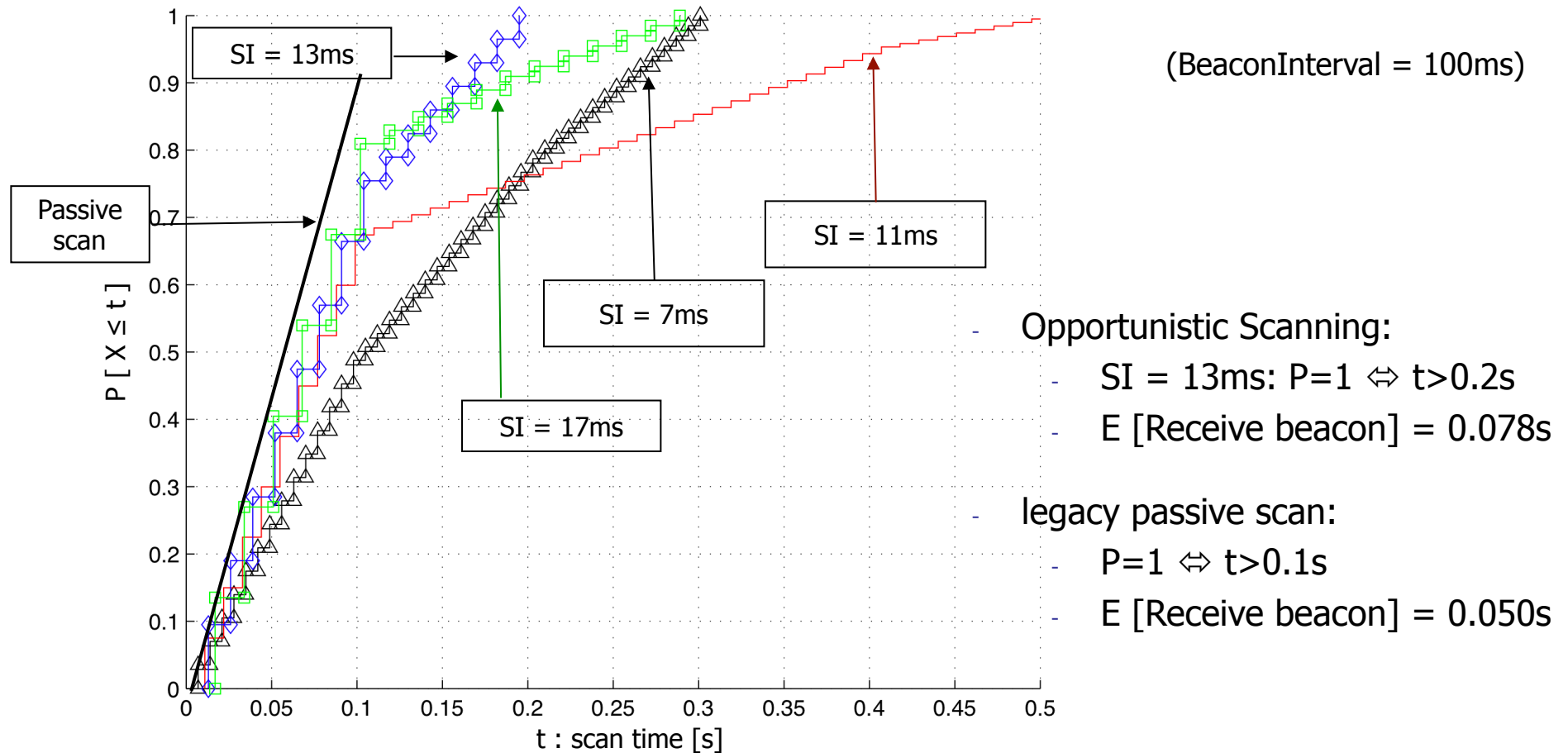

The upper bounds of these results represent a *guarantee to detect existing Access Points* on other frequencies in parallel to any ongoing communication on the originating channel *while assuring the QoS constrains of the application at a given probability.*

Open: *Stability of approach against increased network load?*

Influence of background load

- **Evaluate**
 - Performance of Opportunistic Scanning in (high) load situations
 - Delayed beacons
 - Delayed channel access time for both, signaling and data transmission
 - Number of supportable STAs
- **Simulation-based performance evaluation**
 - Two APs having overlapping coverage, operating on different channels
 - One STA within overlap, associated with one AP
 - Stepwise add STAs (one to each AP at a time) uniformly distributed within coverage of AP of corresponding AP
 - All STAs
 - employ the OP Scanning scheme
 - 13ms scanning interval (also evaluated for 23, 31, and 51ms)
 - 100ms Beacon interval
 - No rate adaptation, rate fixed to 11Mbps
 - Have a VoIP flow
 - G711
 - 20ms packetization
 - Simulations run with OpnetModeler/Wireless

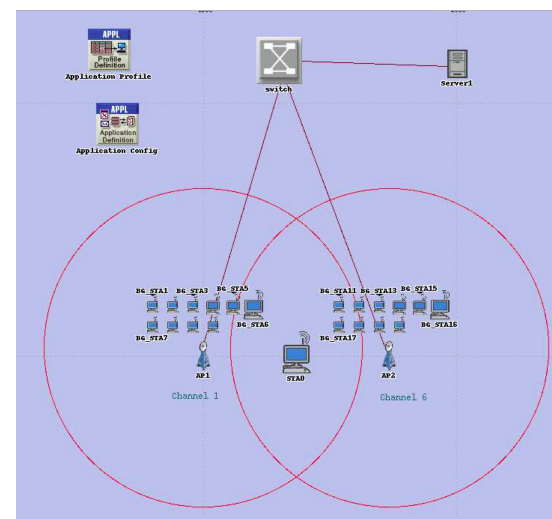

No BG load (single STA): comparison with analysis

- IATs of VoIP packets
 - clustered around 13 & 26 ms
 - Median: 20ms;
P(IAT<50)ms
 - Can be handled with single-packet playout buffer

- **Probability to find beacon**

- Simulation almost reaches theoretical performance
- Difference due to time required to transmit VoIP data (analysis based on sending NULL Data packets)

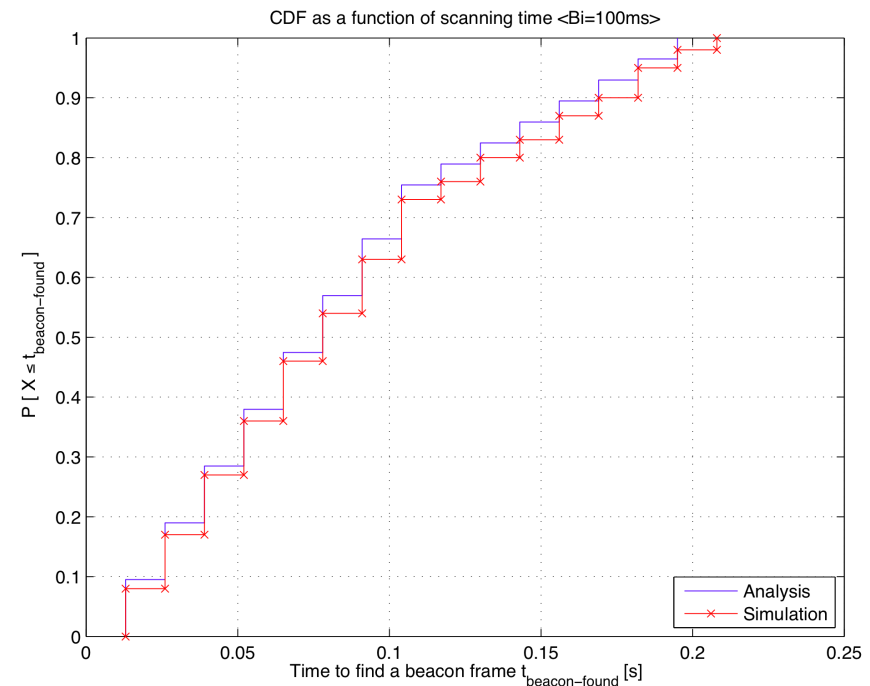
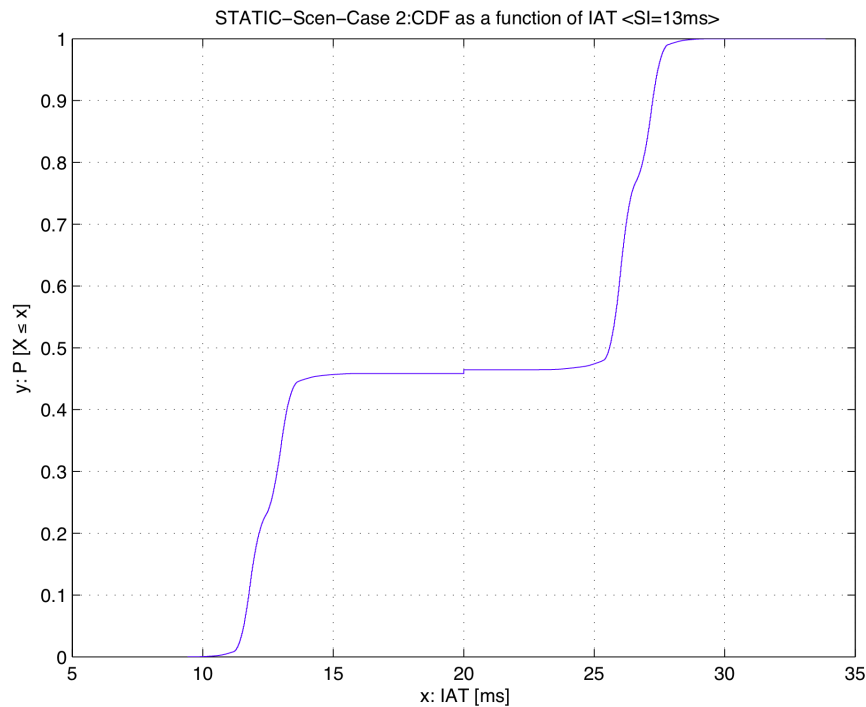

Addition of BG-Load: Packet Loss & IAT

- Up to 9 BG-STAs (=10 in total): no packet loss
- Only one STA less than can be supported without Opportunistic Scanning [2,3]
- BG-Traffic delays medium access
→ media access less deterministic / more evenly distributed
- Median remains at 20ms for 9 BG-STAs or less; also $P(\text{IAT} < 50\text{ms}) = 1$

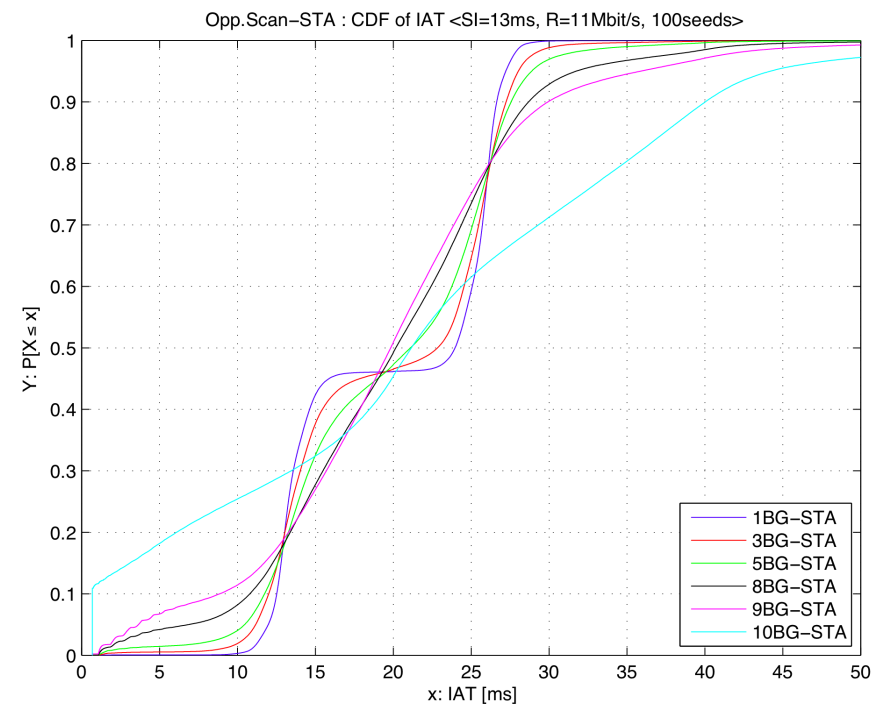
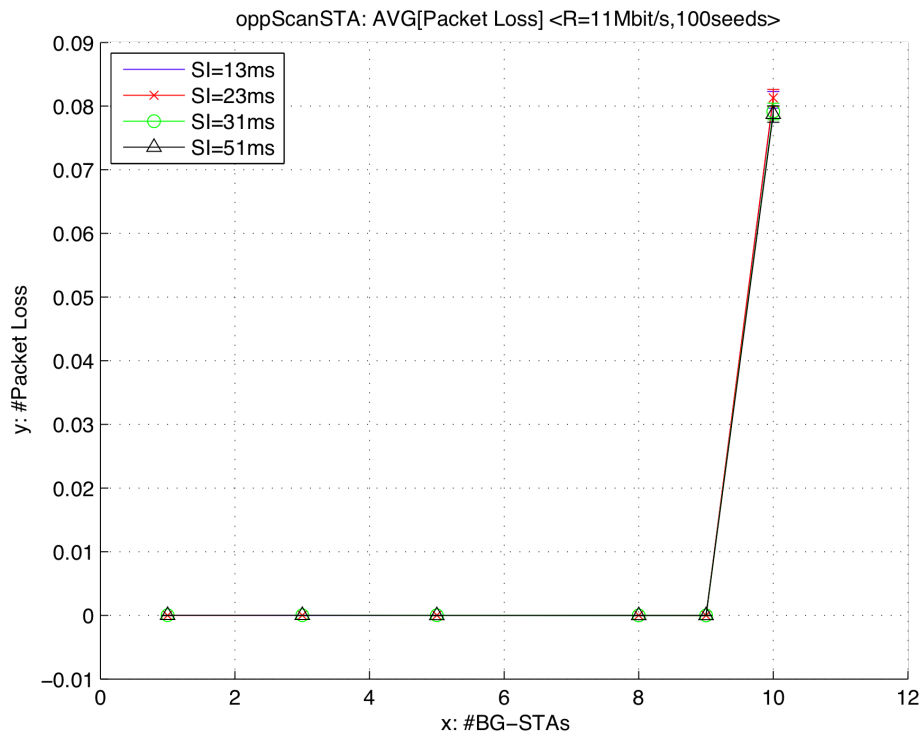

Details on Protocol Performance

- **Data exchange duration vs. scan duration**
 - Increased backload \rightarrow more frequently several packets in the queue
 - \rightarrow burst of packets in PS-Poll sequence
 - \rightarrow effective scan duration reduced (sometimes, even no scan at all)

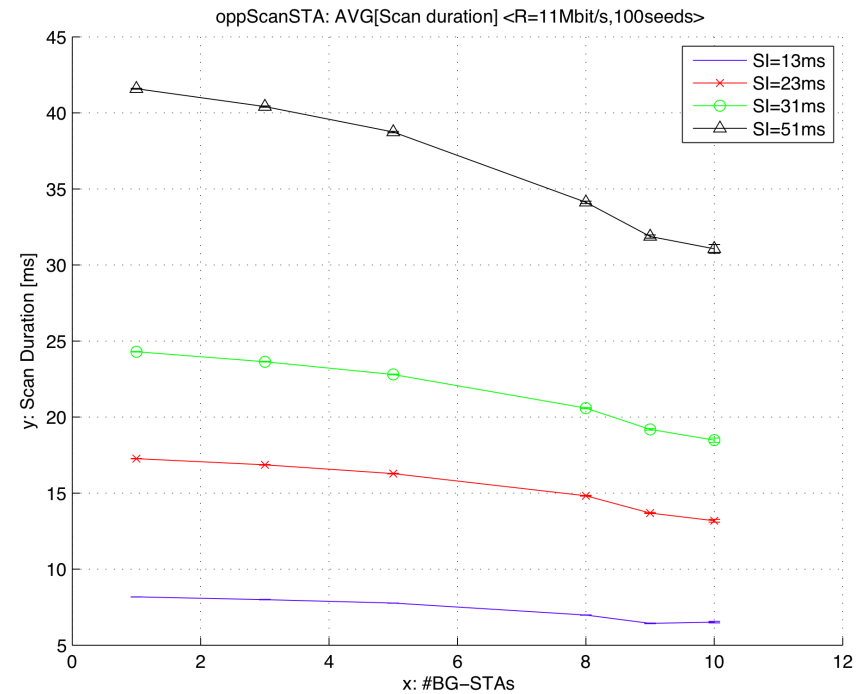
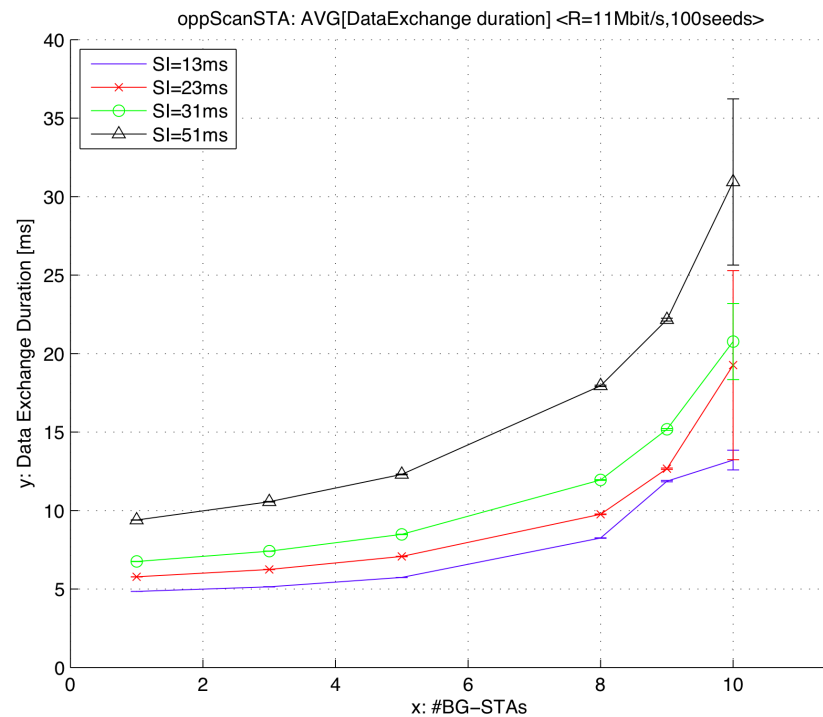

Probability to find Beacon within given time span

- **BG-load has very low influence on time to find a beacon for a reliability of 60% or less**
- **For high reliability (>99%), Opportunistic Scanning can still guarantee detection of existing beacons in less than 1.8s**
- **This detection guarantee is always achieved while guaranteeing a median IAT of 20 ms for the given scenario (VoIP connection)**

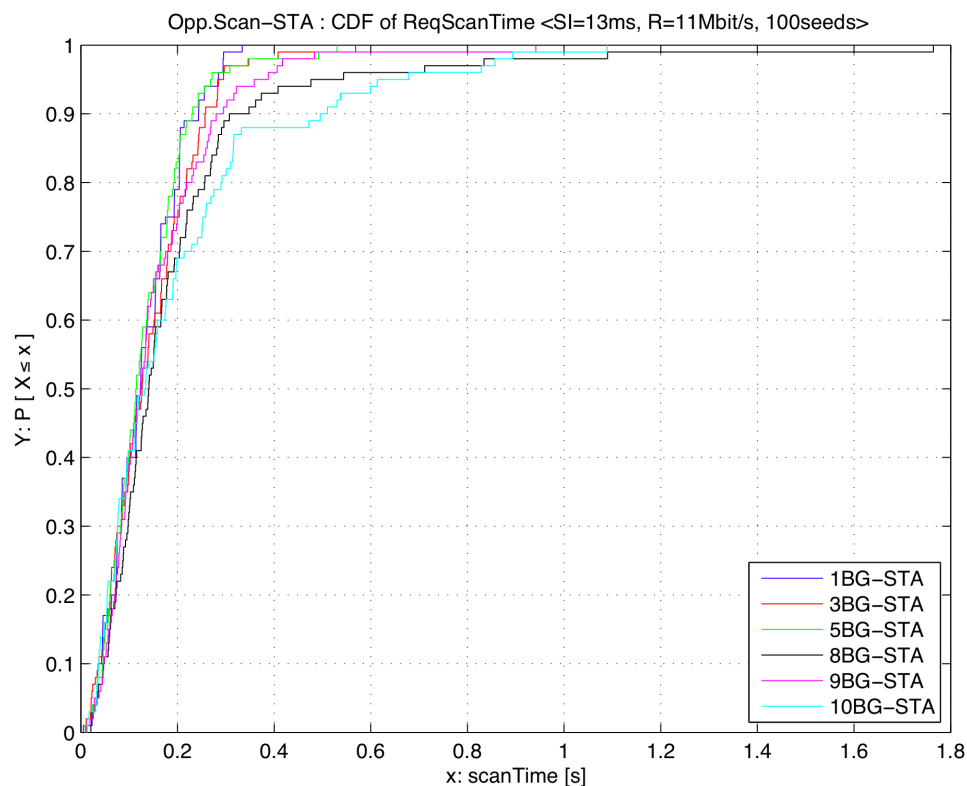

Summary

- **Opportunistic scanning can offer continuous network discovery while restricting service interruption times to a level not affecting higher layer real-time applications and can be implemented without modifying the 802.11 standard**
- **Further work: the missing step**

Nomadic Users → Mobile Users

Where are the performance limits of Opportunistic Scanning for (very) high velocities?

Preliminary results show, that there is an impact ...

→ A future study group for (high) mobility support has to carefully evaluate existing and new mechanisms for several velocities / for a set of very well defined scenarios.

References

- [1] M. Emmelmann, S. Wiethölter, and H.-T. Lim. **Opportunistic Scanning: Interruption-Free Network Topology Discovery for Wireless Mesh Networks**. In Proc. of International Symposium on a World of Wireless, Mobile and Multimedia Networks (IEEE WoWMoM), Kos, Greece, June 15-19, 2009. (available online at <http://www.emmelmann.org/Pages/Publications.html>)
- [2] Garg et al. "Can I add a VoIP call"
- [3] S. Wiethölter, "Virtual Utilization and VoIP Capacity of WLANs Supporting a Mix of Data Rates", Technical Report TKN-05-004, Telecommunication Networks Group, Technische Universität Berlin, September 2005.
- [4] M. Emmelmann, S. Wiethölter, and H.-T. Lim. **A management method for communication devices and a communication device – employing opportunistic scanning for architecture, system and technology discovery**. Pending Patent US 61/186,528.
- [5] M. Emmelmann, S. Wiethölter, and H.-T. Lim. **Influence of Network Load on the Performance of Opportunistic Scanning**. In Proc. of IEEE Conference on Local Computer Networks (LCN), Zürich, Switzerland, Oct 20-23, 2009. ISBN 978-1-4244-4487-8. (available online at <http://www.emmelmann.org/Pages/Publications.html>)
- [6] Hitoshi Morioka, Hirshi Mano, and Hiroki Nakano. **IEEE 802.11 for high speed mobility**. IEEE 802.11 WNG SC, Doc. # 11-09/1000r0. Hawaii, USA, September 2009.
- [7] Woon Cho, Sang Woo Lee, and Hyun Seo Oh. **Enhancement Technology for Vehicular Communication**. IEEE 802.11 WNG SC, Doc. # 11-09/832r2. Hawaii, USA, September 15, 2009.

Questions?

Straw Poll

- **Should IEEE 802.11 WNG receive further presentations analyzing if existing mechanism can be used to support seamless handoff for (highly) mobile users?**

- Yes: 21
- No: 0
- Abstain: 4

Annex: Further simulation results

- **Influence of beacon interval on probability to detect a beacon with Opportunistic Scanning**

Probability to detect a beacon: Influence of Beacon Interval (BI)

- Scan Interval: 20ms (typical for VoIP G711 20ms packetization)

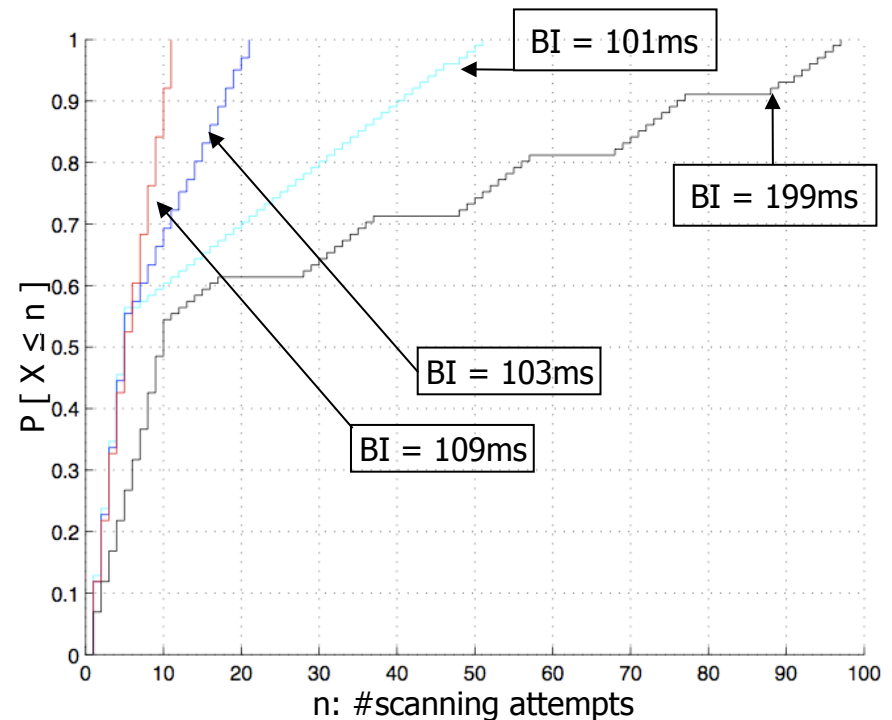
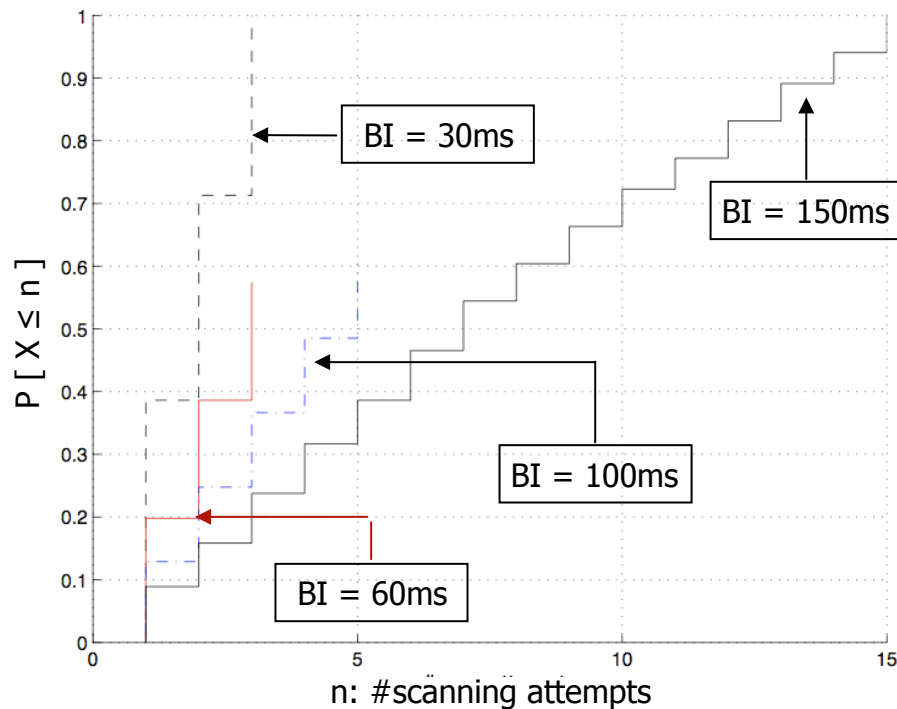

- Small BIs better but
- If BI and SI are not prime to each other, beacon's reception cannot be guaranteed

- Using primes as BIs guarantees that success (eventually)
- Smallest value not necessarily the best choice